

### Face Milling Tools · Planfräser

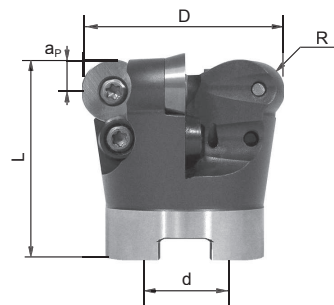

## FMR04 P M K



Depo-System

Type Typ	Stock Lager	Dimension (mm) Abmessung					No. of teeth Zähne	
		Ø D	Ø d	L	R	apmax		
<b>FMR04</b>	042-A16-RD1003-06	•	42	16	44	5	5	6
	042-A16-RD1003-06C	•	42	16	44	5	5	6
	052-A22-RD1003-07	•	52	22	50	5	5	7
	052-A22-RD1003-07C	•	52	22	50	5	5	7

Inserts · WSP: RDKW1003MO\*\*

Type Typ	Stock Lager	Dimension (mm) Abmessung					No. of teeth Zähne	
		Ø D	Ø d	L	R	apmax		
<b>FMR04</b>	042-A16-RD12T3-05	•	42	16	42	6	6	5
	042-A16-RD12T3-05C	•	42	16	42	6	6	5
	052-A22-RD12T3-05	•	52	22	50	6	6	5
	052-A22-RD12T3-05C	•	52	22	50	6	6	5
	066-A27-RD12T3-06	•	66	27	50	6	6	6
	066-A27-RD12T3-06C	•	66	27	50	6	6	6
	080-A27-RD12T3-07	•	80	27	50	6	6	7
	080-A27-RD12T3-07C	•	80	27	50	6	6	7

Inserts · WSP: RDKW12T3MO\*\*













Type Typ	Stock Lager	Dimension (mm) Abmessung					No. of teeth Zähne	
		Ø D	Ø d	L	R	apmax		
<b>FMR04</b>	*052-A22-RD1604-04	•	52	22	50	8	8	4
	*052-A22-RD1604-04C	•	52	22	50	8	8	4
	*052-A22-RD1604-05	•	52	22	50	8	8	5
	*052-A22-RD1604-05C	•	52	22	50	8	8	5
	066-A27-RD1604-05	•	66	27	50	8	8	5
	066-A27-RD1604-05C	•	66	27	50	8	8	5
	080-A27-RD1604-06	•	80	27	52	8	8	6
	080-A27-RD1604-06C	•	80	27	52	8	8	6
	100-B32-RD1604-07	•	100	32	52	8	8	7
	100-B32-RD1604-07C	•	100	32	52	8	8	7
	125-B40-RD1604-08	•	125	40	52	8	8	8
	125-B40-RD1604-08C	•	125	40	52	8	8	8
	160-B40-RD1604-09	•	160	40	52	8	8	9
	160-B40-RD1604-09C	○	160	40	52	8	8	9

Inserts · WSP: RDKW1604MO\*\*

\*= WX16N (außer für FMP04-052) (except for FMP04-052)

\*\*= nur ab (Ø 052) from (Ø 052)

### Spare Parts · Ersatzteile

Type Typ	Screw Schraube	Clamp Klemmscheibe	Clamp Screw Klemmschraube	Wrench Schlüssel
FMR04**RD1003	 I60M3,5 x 7,7	 -	 -	 WT15P
FMR04**RD12T3	 I60M3,5 x 7,7	 -	 **LOM 3,5 x 7,1	 WT15P
FMR04**RD1604	 I60M4,5 x 1,0	 *WX16N	 -	 WT20T

Applicable tool  B11-B18  
Werkzeug

Tools code key  B26-B27  
Werkzeug ISO

Grade selection guide  B19-B23  
Sortenauswahl

Technical data  B215-B220  
Technische Daten