

TC** Toolholder · Halter

S-Clamping · S-Halter

STACR/ L

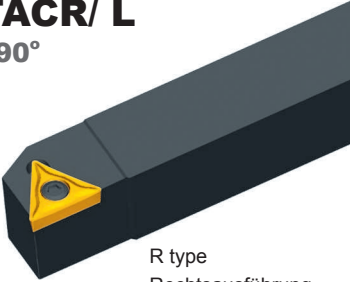

Kr:90°

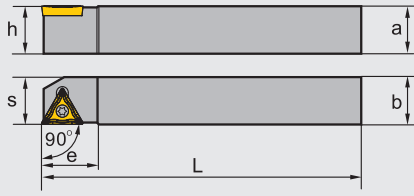

R type
Rechtsausführung

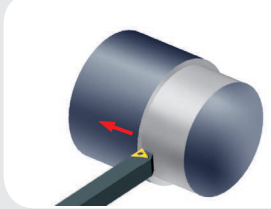





Type · Typ		Stock Lager		Dimension (mm) Abmessung						Screw Schraube	Wrench Schlüssel		
		R	L	a	b	L	h	s	e				
STACR/ L	1212F11	●	●	12	12	80	12	12.5	14	I60M2.5×6.5	WT07IP		

STFCR/ L

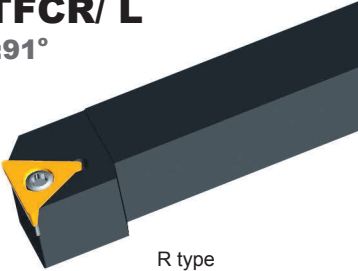



Kr:91°



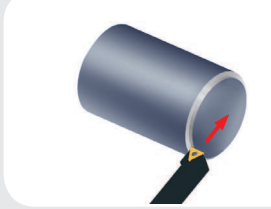







R type
Rechtsausführung



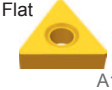
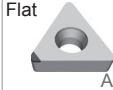

Type · Typ		Stock Lager		Dimension (mm) Abmessung						Screw Schraube	Shim Unterlage	Shim Screw, Unterlage Schraube	Wrench Schlüssel
		R	L	a	b	L	h	s	e				
STFCR/ L	1212F11	●	●	12	12	80	12	16	14	I60M2.5×6.5	—	—	WT07IP
	1616H11	●	●	16	16	100	16	20	14				
	1616H16	●	●	16	16	100	16	20	19	I60M3.5×12	T16BS	SM5×8.65XA	WT15IP WH35L
	2020K16	●	●	20	20	125	20	25	19				

Applicable insert Wendeschneidplatten

Application Anwendung	Extra Finishing Feinbearbeitung	Finishing Schlichten	Semi-finishing Mittlere Bearbeit.	Roughing Schruppen	Al machining Alu Bearbeitung	Cast iron machining	PCBN/PCD inserts/WSP
insert shape Schneidplattenform	SF  A106	HF  A107	HM  A109	HR  A109	LH  A110	Flat  A109	Flat  A129
		EF  A107	EM  A108		LC  A110		
Type · Typ	STACR/ L**F11	TC**1102**	TC**1102**	TC**1102**	TC**1102**	TCGX1102**	TC**1102**
	STFCR/ L**F/ H11	TC**1102**	TC**1102**	TC**1102**	TC**1102**	TCGX1102**	TC**1102**
	STFCR/ L**H/ K16		TC**16T3**	TC**16T3**	TC**16T3**	TCGX16T3**	TC**16T3**

Turning · Drehen

External turning tools · Drehwerkzeugen zur Außenbearbeitung

A

General Turning · Allgemeine Drehbearbeitung

TC** Toolholder · Halter

S-Clamping · S-Halter

STGCR/ L

Kr:91°

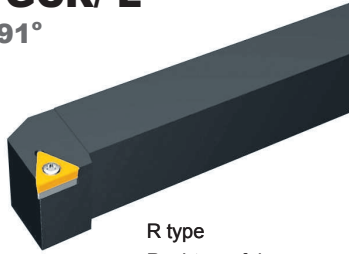



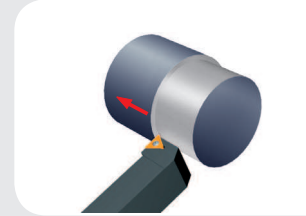
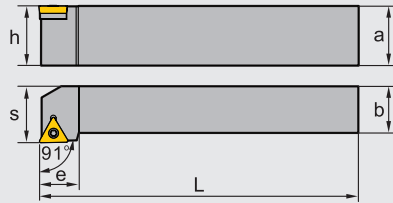







R type
Rechtsausführung



Type · Typ		Stock Lager		Dimension (mm) Abmessung						Screw Schraube	Shim Unterlage	Shim Screw, Unterlage Schraube	Wrench Schlüssel
		R	L	a	b	L	h	s	e				
STGCR/ L	0808D09	●	●	08	08	60	8	10	11	I60M2.2×5.5	—	—	WT06IP
	1010E09	●	●	10	10	70	10	12	11				
	1212F11	●	●	12	12	80	12	16	14				
	1616H11	●	●	16	16	100	16	20	16	I60M2.5×6.5	—	—	WT07IP
	2020K16	●	●	20	20	125	20	25	21				
	2525M16	●	●	25	25	150	25	25	21	I60M3.5×12	T16BS	SM5×8.65XA	WT15IP WH35L

Applicable insert
Wendeschneidplatten

Application Anwendung	Extra Finishing Feinbearbeitung	Finishing Schlichten	Semi-finishing Mittlere Bearbeit.	Roughing Schruppen	Al machining Alu Bearbeitung	Cast iron machining	PCBN/PCD inserts/WSP	
insert shape Schneidplattenform	SF  A106	HF  A107	HM  A109	HR  A109	LH  A110	Flat  A109	Flat  A129	
		EF  A107	EM  A108		LC  A110			
Type · Typ	STGCR / L**D / E09	TC**0902**	TC**0902**	TC**0902**	TC**0902**	TCGX0902**	TC**0902**	TC**0902**
	STGCR / L**F / H11	TC**1102**	TC**1102**	TC**1102**	TC**1102**	TCGX1102**	TC**1102**	TC**1102**
	STGCR / L**K / M16		TC**16T3**	TC**16T3**	TC**16T3**	TCGX16T3**	TC**16T3**	TC**16T3**

● ex stock · ab Lager ○ on demand · Anfrage

TC** Toolholder · Halter

S-Clamping · S-Halter



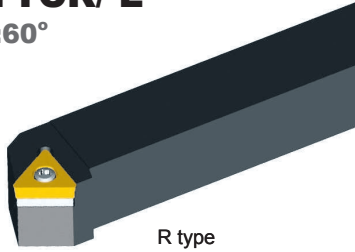

STTCR/ L

Kr:60°

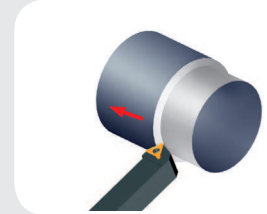











R type
Rechtsausführung



Type · Typ		Stock Lager		Dimension (mm) Abmessung						Screw Schraube	Shim Unterlage	Shim Screw, Unterlage Schraube	Wrench Schlüssel
		R	L	a	b	L	h	s	e				
STTCR/ L	1616H11	●	●	16	16	100	16	13	14	I60M2.5×6.5	—	—	WT07IP
	1616H16	●	●	16	16	100	16	13	19	I60M3.5×12	T16BS	SM5×8.65XA	WT15IP
	2020K16	●	●	20	20	125	20	17	19				WH35L

Applicable insert
Wendeschneidplatten

Application Anwendung	Extra Finishing Feinbearbeitung	Finishing Schlichten	Semi-finishing Mittlere Bearbeit.	Roughing Schruppen	Al machining Alu Bearbeitung	Cast iron machining	PCBN/PCD inserts/WSP	
insert shape Schneidplattenform	SF  A106	HF  A107	HM  A109	HR  A109	LH  A110	Flat  A109	Flat  A129	
		EF  A107	EM  A108		LC  A110			
Type · Typ	STTCR / L**H11	TC**1102**	TC**1102**	TC**1102**	TC**1102**	TCGX1102**	TC**1102**	TC**1102**
	STTCR / L**H / K16		TC**16T3**	TC**16T3**	TC**16T3**	TCGX16T3**	TC**16T3**	TC**16T3**

Turning · Drehen

Internal turning tools · Drehwerkzeuge zur Innenbearbeitung

TC** Toolholder · Halter

S-Clamping / S-Halter

STFCR/L Kr:91°/*Kr:90°

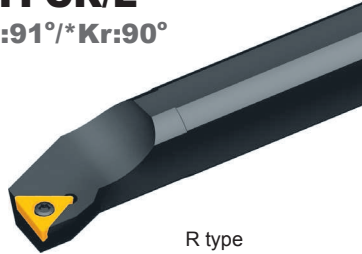



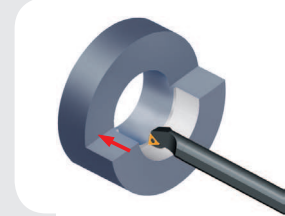
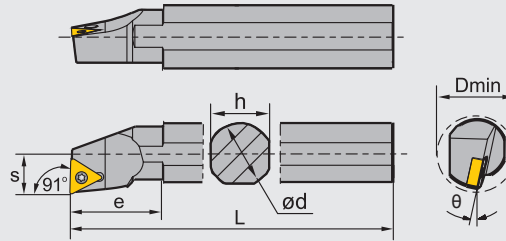





R type
Rechtsausführung



Type · Typ	Stock Lager		Dimension (mm) Abmessung							Screw Schraube	Wrench Schlüssel	Shim Unterlage	Shim/ Screw Schraube Unterlage
	R	L	Dmin	ød	h	L	S	θ	e				
S12M-STFCR/L11	●	●	16	12	11	150	9	-10°	30	I60M2.5×6.5	WT07IP		
S16M-STFCR/L11	○	○	20	16	15	150	11	-6°	35				
S16R-STFCR/L11	●	●	20	16	15	200	11	-6°	35				
S20Q-STFCR/L11	○	○	25	20	18	180	13	-3°	36				
S20S-STFCR/L11	●	●	25	20	18	250	13	-3°	36				
S25Q-STFCR/L16	○	○	32	25	23	180	17	-6°	49	I60M3.5×10	WT15IP		
S25T-STFCR/L16	●	●	32	25	23	300	17	-6°	49				
S32R-STFCR/L16	○	○	40	32	30	200	22	-10°	50	I60M3.5×12	WT15IP WH35L	T16BS	SM5×8.65XA
S32U-STFCR/L16	●	●	40	32	30	350	22	-10°	50				
S40S-STFCR/L16	○	○	50	40	37	250	27	-8°	60				
S40V-STFCR/L16	●	●	50	40	37	400	27	-8°	60				
♦ A12K-STFCR/L11	●	●	16	12	11.5	125	9	-10°	26	I60M2.5×6.5	WT07IP		
♦ A16M-STFCR/L11	●	○	20	16	15.5	150	11	-6°	30				
♦ A20Q-STFCR/L11	●	●	25	20	19	180	13	-3°	36				
♦ A25R-STFCR/L16	●	●	32	25	24	200	17	-6°	45				
♦ A32S-STFCR/L16	●	○	40	32	31	250	22	-10°	49				

Applicable insert
Wendeschneidplatten

Application Anwendung	Extra Finishing Feinbearbeitung	Finishing Schlichten	Semi-finishing Mittlere Bearbeit.	Roughing Schruppen	Al machining Alu Bearbeitung	Cast iron machining Grauguss Bearbeit.	
insert shape Schneidplattenform	SF  A106	HF  A107	HM  A109	HR  A109	LH  A110	Flat  A109	
		EF  A107	EM  A108		LC  A110		
Type · Typ	**STFCR/L11	TC**1102**	TC**1102**	TC**1102**	TC**1102**	TCGX1102**	TC**1102**
	STFCR/L16	TC16T3**	TC**16T3**	TC**16T3**	TC**16T3**	TCGX16T3**	TC**16T3**

● ex stock · ab Lager ○ on demand · auf Anfrage ♦ Toolholder with holes for coolant · Klemmhalter mit Kühlmittelbohrung