

# Turning · Drehen

Threading tools · Gewindedrehwerkzeuge





A

Parting & Grooving · Ab- & Einstechen

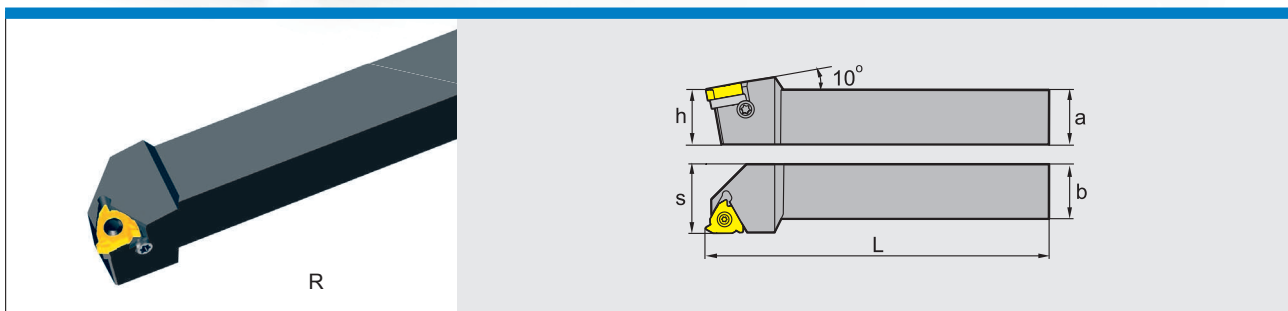
Threading · Gewindedrehen

## External threading tools · Außengewindehalter



Type · Typ		Stock Lager	Dimension (mm) Abmessung					Inserts Wendschneidplatten	Screw Schraube	Shim Unterlage	Shim screw Schraube	Wrench Schlüssel
			a	h	b	L	s					
SWR	1616H16	●	16	16	16	100	20	RT16.01W-****	I60M3.5×12	MT16-**M	SM4×8C	WT15IP
	2020K16	●	20	20	20	125	25					
	2525M16	●	25	25	25	150	32					
	3225P16	●	32	32	25	170	32					
	3232P16	●	32	32	32	170	40	RT22.01W-****	I60M5×17	MT22-**M	SM4×8C	WT15IP WT20IP
	2525M22	●	25	25	25	150	32					
	3225P22	○	32	32	25	170	32					
	3232P22	●	32	32	32	170	40					
4040S22	○	40	40	40	250	50	LT22.01W-****	I60M5×17	MT22-**M	SM4×8C	WT15IP WT20IP	
SWL	1616H16	●	16	16	16	100						20
	2020K16	●	20	20	20	125						25
	2525M16	●	25	25	25	150						32
	3225P16	●	32	32	25	170						32
	3232P16	○	32	32	32	170						40
	2525M22	●	25	25	25	150						32
	3225P22	○	32	32	25	170						32
	3232P22	●	32	32	32	170	40					
4040S22	○	40	40	40	250	50						

● ex stock · ab Lager ○ on demand · auf Anfrage

### Internal threading tools · Innengewindehalter

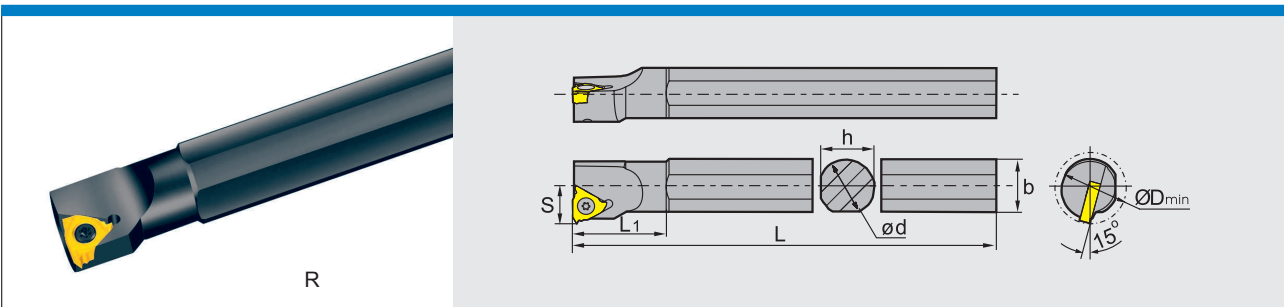

Type · Typ		Stock Lager	Dimension (mm) Abmessung						Inserts Wendeschneidplatten	Screw Schraube	Shim Unterlage	Shim screw Schraube	Wrench Schlüssel	
			d	L	b	Dmin	s	h						L1
SNR	0016K11	●	16	125	16	12	10	15	20.9	LT11.01N-****	I60 M2.5×6.5	---	---	WT07IP
	0016M11	●	16	150	15.5	16	10.5	15	25.9					
	0016M16	●	16	150	15.5	20	12	15	27					
	0020M16	●	20	150	19	25	14	18	28.7	LT16.01N-****	I60 M3.5×8	---	---	WT15IP
	0020Q16	●	20	180	19	25	14	18	34					
	0025M16	●	25	150	24	32	17	23	28.8					
	0032R16	●	32	200	31	40	22	30	30.9					
	0032S16	●	32	250	31	40	22	30	30.9					
	0040T16	●	40	300	38.5	50	27	37	31.5					
	0050U16	○	50	350	49.5	63	35	49	40.2					
	0020Q22	○	20	180	21.5	25	15	18	35	LT22.01N-****	I60 M5×10	---	---	WT20IP
	0025R22	●	25	200	24	32	19	23	39					
	0032S22	●	32	250	31	40	22	30	36.4					
	0040T22	○	40	300	38.5	50	27	37	37.2					
0050U22	●	50	350	48.5	63	35	47	42.6						
SNL	0016K11	●	16	125	16	12	10	15	20.9	RT11.01N-****	I60 M2.5×6.5	---	---	WT07IP
	0016M11	●	16	150	15.5	16	10.5	15	25.9					
	0016M16	●	16	150	15.5	20	12	15	27					
	0020M16	○	20	150	19	25	14	18	28.7	RT16.01N-****	I60 M3.5×8	---	---	WT15IP
	0020Q16	●	20	180	19	25	14	18	34					
	0025M16	●	25	150	24	32	17	23	28.8					
	0032R16	○	32	200	31	40	22	30	30.9					
	0032S16	○	32	250	31	40	22	30	30.9					
	0040T16	●	40	300	38.5	50	27	37	31.5					
	0050U16	○	50	350	49.5	63	35	49	40.2					
	0020Q22	○	20	180	21.5	25	15	18	35	RT22.01N-****	I60 M5×10	---	---	WT20IP
	0025R22	○	25	200	24	32	19	23	39					
	0032S22	○	32	250	31	40	22	30	36.4					
	0040T22	○	40	300	38.5	50	27	37	37.2					
0050U22	●	50	350	48.5	63	35	47	42.6						

● ex stock · ab Lager ○ on demand · auf Anfrage

# Turning · Drehen

Threading tools · Gewindedrehwerkzeuge

## External threading tools Außen Gewindhalter

Thin Type

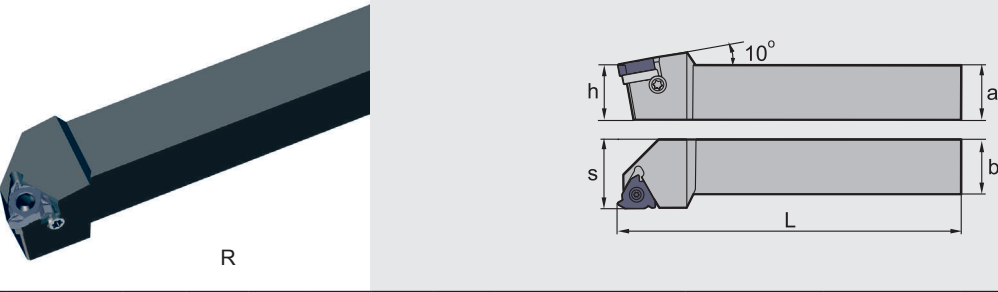

Type · Typ	Stock Lager	Dimension (mm) Abmessung					Inserts Wendeschneidplatten	Screw Schraube	Shim Unterlage	Shim screw Schraube	Wrench Schlüssel
		a	h	b	L	s					
SWR	1616H16B	○	16	16	16	100	RT16.01W-****B	I60M3.5×12B	MT16-**M	SM4×8C	WT15IP
	2020K16B	○	20	20	20	125					
	2525M16B	○	25	25	25	150					
	3225P16B	○	32	32	25	170					
	3232P16B	○	32	32	32	170					

## Internal threading tools Innengewindhalter

Thin Type

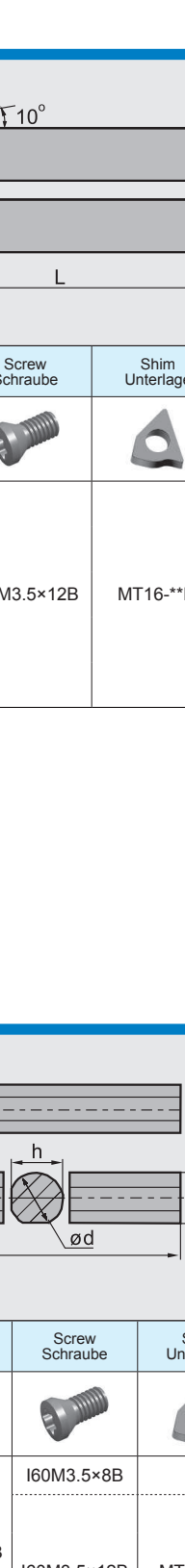

Type · Typ	Stock Lager	Dimension (mm) Abmessung							Inserts Wendeschneidplatten	Screw Schraube	Shim Unterlage	Shim screw Schraube	Wrench Schlüssel	
		d	L	b	D <sub>min</sub>	s	h	L <sub>1</sub>						
SNR	0016M16B	○	16	150	15.5	20	12	15	27	LT16.01N-□□□□B	I60M3.5×8B	—	—	WT15IP
	0020Q16B	○	20	180	19	25	14	18	34					
	0025M16B	○	25	150	24	32	17	23	28.8		I60M3.5×12B	MT16-**M	SM4×8C	
	0032R16B	○	32	200	31	40	22	30	30.9					
	0032S16B	○	32	250	31	40	22	30	30.9					

● ex stock · ab Lager ○ on demand · auf Anfrage