

# Turning · Drehen

Parting & Grooving · Ab- & Einstechen

## Blade for external parting · Abstechschwert zur Außenbearbeitung

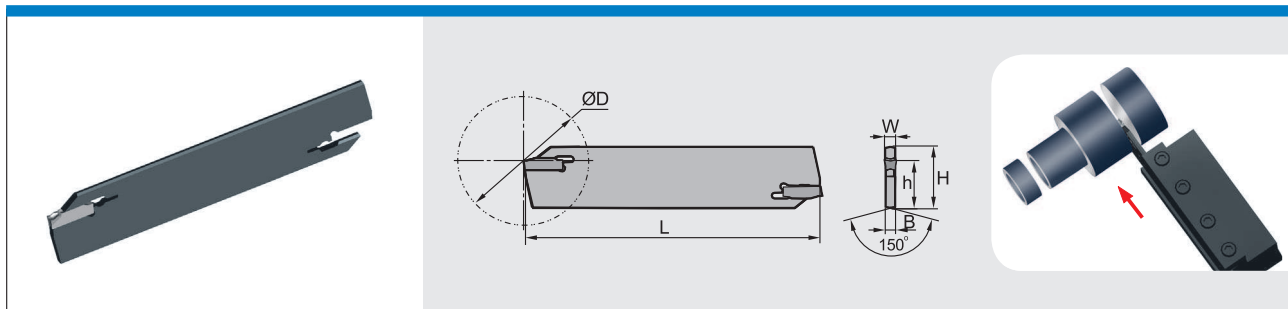

Type Typ	Stock Stock	Dimension (mm) Abmessung						Inserts Stechplatten	Wrench Schlüssel
		L	H	h	B	W	ØD max		
QEES26N	●	110	26	19	2	2.5	60	ZPES02502-MG	W50RL
QEFS26N	●	110	26	19	2.4	3	60	ZPFS0302-MG	
QEGS26N	●	110	26	19	3.2	4	70	ZPGS0402-MG	
QEHS26N	●	110	26	19	4	5	70	ZPHS0503-MG	
QEKS26N	●	110	26	19	5	6	70	ZPKS0604-MG	
QEES32N	●	150	32	24.6	2	2.5	100	ZPES02502-MG	
QEFS32N	●	150	32	24.6	2.4	3	100	ZPFS0302-MG	
QEGS32N	●	150	32	24.6	3.2	4	120	ZPGS0402-MG	
QEHS32N	●	150	32	24.6	4	5	120	ZPHS0503-MG	
QEKS32N	●	150	32	24.6	5	6	120	ZPKS0604-MG	

## Holder for external parting · Spannblock zur Außenbearbeitung

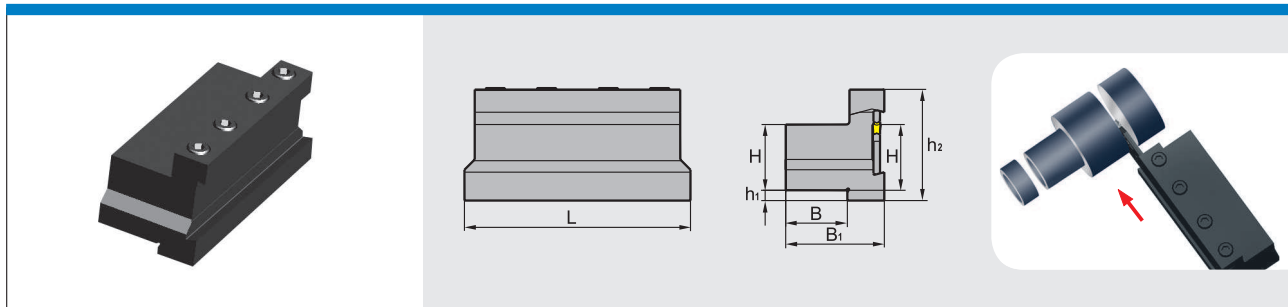

Type Typ	Stock Stock	Dimension (mm) Abmessung						Clamp Klemme	Screw Schraube	Wrench Schlüssel
		L	H	h <sub>1</sub>	h <sub>2</sub>	B	B <sub>1</sub>			
QZS2026	●	86	20	10	46.6	19	38	QZC26	GB70-85-M6×20	WH50L
QZS2526	●	86	25	5	46.6	23	42	QZC26		
QZS3226	○	86	32	3	51.6	30	48	QZC26		
QZS2032	●	110	20	13	50	19	38	QZC32		
QZS2532	●	110	25	8	50	23	42	QZC32		
QZS3232	●	110	32	5	54	30	48	QZC32		

● ex stock · ab Lager ○ on demand · auf Anfrage