

### Face Milling Tools · Planfräser

Kr:90°

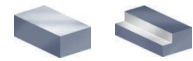

**FMP01** **P** **M** **K**

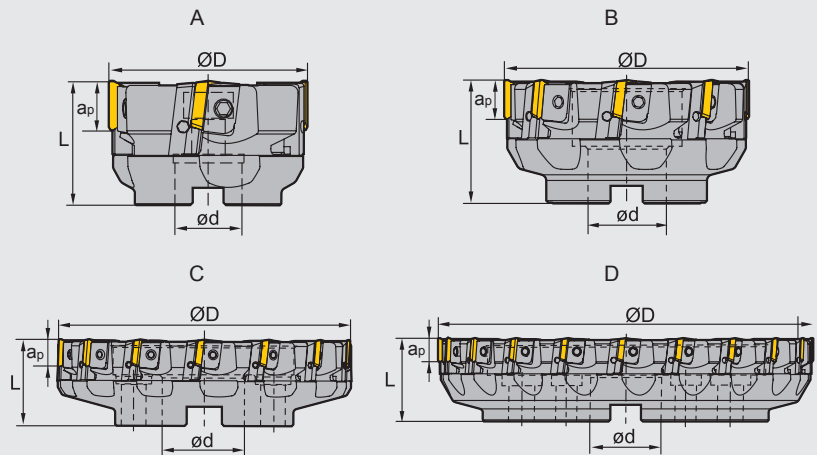

#### Specification of tools · Werkzeug Beschreibung

| Type Typ         | Stock Lager | Dimension (mm) Abmessung |   |     |     |    |       | No. of teeth Zähne | Coupling Aufnahme | Weight Gewicht (kg) |
|------------------|-------------|--------------------------|---|-----|-----|----|-------|--------------------|-------------------|---------------------|
|                  |             | R                        | L | Ø D | Ø d | L  | apmax |                    |                   |                     |
| <b>FMP01</b>     |             |                          |   |     |     |    |       |                    |                   |                     |
| -080-A27-TP22-04 | ● ○         |                          |   | 80  | 27  | 50 | 18    | 4                  | A                 | 1.2                 |
| -100-B32-TP22-06 | ● ○         |                          |   | 100 | 32  | 50 | 18    | 6                  | B                 | 1.7                 |
| -125-B40-TP22-08 | ● ○         |                          |   | 125 | 40  | 63 | 18    | 8                  | B                 | 3.2                 |
| -160-B40-TP22-10 | ● ○         |                          |   | 160 | 40  | 63 | 18    | 10                 | B                 | 5.1                 |
| -200-C60-TP22-12 | ● ○         |                          |   | 200 | 60  | 63 | 18    | 12                 | C                 | 7.4                 |
| -250-C60-TP22-16 | ○ ○         |                          |   | 250 | 60  | 63 | 18    | 16                 | C                 | 12.3                |
| -315-D60-TP22-20 | ○ ○         |                          |   | 315 | 60  | 70 | 18    | 20                 | D                 | 21.9                |

#### Spare Parts · Ersatzteile

| Diameter Durchmesser Ø D | Cassette Kassette | Wedge Keil | Screw Schraube | Locator screw Schraube | Wrench Schlüssel |  |
|--------------------------|-------------------|------------|----------------|------------------------|------------------|--|
| Ø80 Ø100                 | LTP4R1/L1         | W04R/L     | WM8×17         | LOM5×15.1              | WT20T            |  |
| Ø125 ~ Ø315              | LTP4R/L           |            | WM8×22         |                        | WT25T            |  |
|                          |                   |            |                |                        |                  |  |

● Ex Stock / ab Lager ○ On demand / auf Anfrage