

Face Milling Tools · Planfräser

Kr:45°

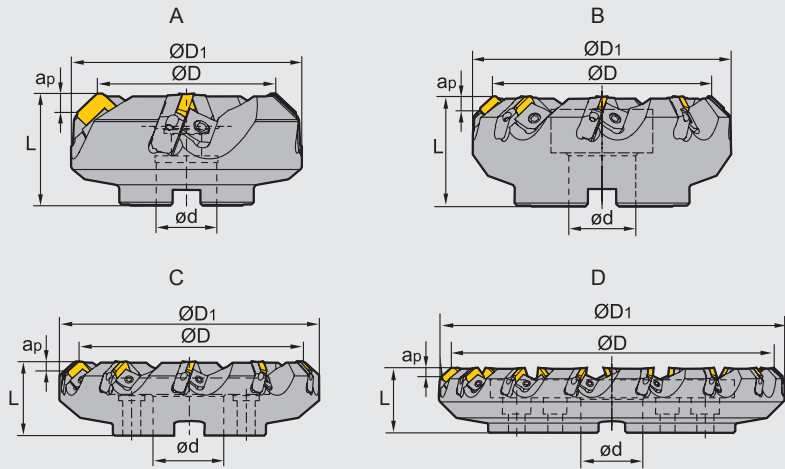

FMA03 P M K

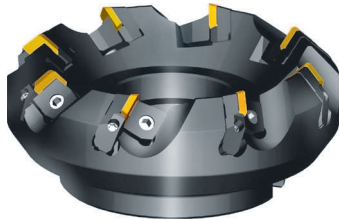

Specification of tools · Werkzeug Beschreibung

Type · Typ	Stock Lager	Dimension (mm) Abmessung						No. of teeth Zähne	Coupling Aufnahme	Weight Gewicht (kg)	
		R	L	Ø D	Ø D ₁	Ø D	L				ap _{max}
FMA03 -080-A27-SE12-04	○ ○			80	103	27	50	5.5	4	A	1.8
-100-B32-SE12-05	○ ○			100	122	32	50	5.5	5	B	2.4
-125-B40-SE12-06	○ ○			125	147	40	63	5.5	6	B	4.4
-160-B40-SE12-08	○ ○			160	181	40	63	5.5	8	B	6.4
-200-C60-SE12-10	○ ○			200	221	60	63	5.5	10	C	8.5
-250-C60-SE12-12	○ ○			250	270	60	63	5.5	12	C	14.1
-315-D60-SE12-15	○ ○			315	353	60	63	5.5	15	D	22.2
-080-A27-SE15-04	○ ○			80	103	27	50	7.5	4	A	1.7
-100-B32-SE15-05	○ ○			100	122	32	50	7.5	5	B	2.3
-125-B40-SE15-06	○ ○			125	147	40	63	7.5	6	B	4.2
-160-B40-SE15-08	○ ○			160	181	40	63	7.5	8	B	6.1
-200-C60-SE15-10	○ ○			200	221	60	63	7.5	10	C	8.3
-250-C60-SE15-12	○ ○			250	270	60	63	7.5	12	C	13.6
-315-D60-SE15-15	○ ○			315	353	60	63	7.5	15	D	21.8

Parts · Ersatzteile

Diameter Durchmesser Ø D	Insert Platte	Cassette Kassette	Wedge Keil	Wedge screw Keilschraube	Locator screw Schraube	Wrench Schlüssel
Ø80-Ø315	SE12	LSE12R/L	W01R/L	DM8×21X	LOM5×15.1	WT20T WH40T
Ø80-Ø315	SE15	LSE15R/L				

● Ex Stock / ab Lager ○ On demand / auf Anfrage

Applicable tool **B9-B15**
Werkzeug

Tools code key **B22-B23**
Werkzeug ISO

Grade selection guide **B16-B20**
Sortenauswahl

Technical data **B183-B188**
Technische Daten

Milling · Fräsen

Indexable Milling Tools · Wendepplattenfräser

Face Milling Tools · Planfräser

Kr:45°



FMA04 P M K

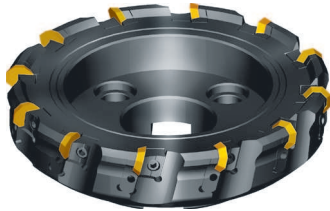

Wedge Keil

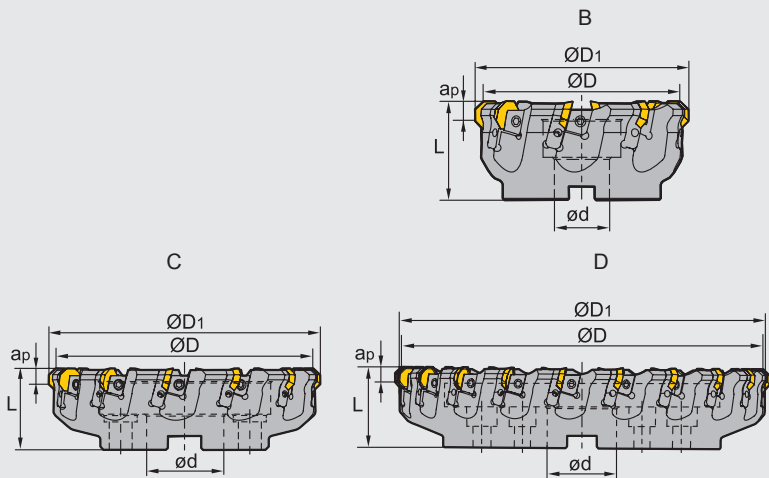

Specification of tools · Werkzeug Beschreibung

Type · Typ	Stock Lager	Dimension (mm) Abmessung							No. of teeth Zähne	Coupling Aufnahme	Weight Gewicht (kg)
		R	L	Ø D	Ø D ₁	Ø D	L	ap _{max}			
FMA04	-125-B40-OF07-08	●	○	125	136	40	63	5	8	B	3.9
	-160-B40-OF07-10	●	○	160	171	40	63	5	10	B	5.9
	-200-C60-OF07-12	●	○	200	211	60	63	5	12	C	7.6
	-250-C60-OF07-16	●	○	250	261	60	63	5	16	C	13.3
	-315-D60-OF07-20	●	○	315	321	60	63	5	20	D	20.3

Parts · Ersatzteile

Diameter Durchmesser Ø D	Cassette Kassette	Wedge Keil	Wedge screw Keilschraube	Locator screw Einstellschraube	Wrench Schlüssel	
Ø125-Ø315	LOF07R/L	W02R/L	DM8×21X	LOM5×15.1	WT20T WH40T	

● Ex Stock / ab Lager ○ On demand / auf Anfrage

Milling · Fräsen

Indexable Milling Tools · Wendeplattenfräser

Face Milling Tools · Planfräser

Kr:75°



FME03 P M K

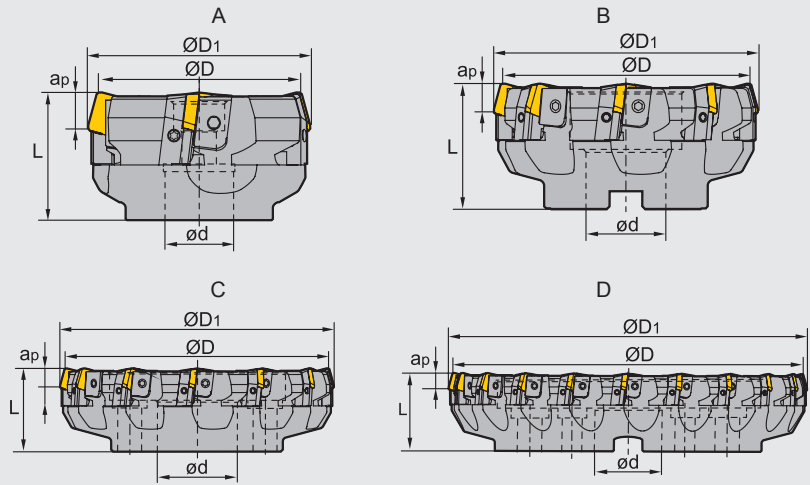
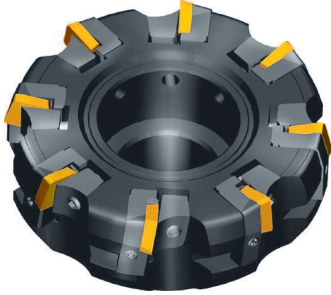

Specification of tools · Werkzeug Beschreibung

Type · Typ	Stock Lager		Dimension (mm) Abmessung					No. of teeth Zähne	Coupling Aufnahme	Weight Gewicht (kg)
	R	L	Ø D	Ø D ₁	Ø D	L	ap _{max}			
FME03 -080-A27-SP12-04	○	○	80	84	27	50	6	4	A	1.1
-100-B32-SP12-06	○	○	100	104	32	50	6	6	B	1.9
-125-B40-SP12-08	○	○	125	129	40	63	6	8	B	3.5
-160-B40-SP12-10	○	○	160	164	40	63	6	10	B	5.7
-200-C60-SP12-12	○	○	200	203	60	63	6	12	C	8.2
-250-C60-SP12-16	○	○	250	253	60	63	6	16	C	13.8
-315-D60-SP12-20	○	○	315	318	60	70	6	20	D	23.5
-080-A27-SP15-04	○	○	80	84	27	50	8	4	A	1.0
-100-B27-SP15-06	○	○	100	104	27	50	8	6	B	1.8
-125-B40-SP15-08	○	○	125	129	40	63	8	8	B	3.3
-160-B40-SP15-10	○	○	160	164	40	63	8	10	B	5.4
-200-C60-SP15-12	○	○	200	204	60	63	8	12	C	7.9
-250-C60-SP15-16	○	○	250	253	60	63	8	16	C	13.6
-315-D60-SP15-20	○	○	315	318	60	70	8	20	D	23.1

Spare Parts · Ersatzteile

Diameter Durchmesser Ø D	Insert Platte	Cassette Kassette	Wedge Keil	Screw Schraube	Locator screw Schraube	Wrench Schlüssel	
Ø80-Ø100	SP12	LSP12R/L	W04R/L	WM8×17	LOM5×15.1	WT20T WT25T	
Ø125-Ø315				WM8×22			
Ø80-Ø315	SP15	LSP15R/L	W04R/L	WM8×22			

● Ex Stock / ab Lager ○ On demand / auf Anfrage

Milling · Fräsen

Indexable Milling Tools · Wendeplattenfräser

Face Milling Tools · Planfräser

Kr:90°



FMP01 **P** **M** **K**

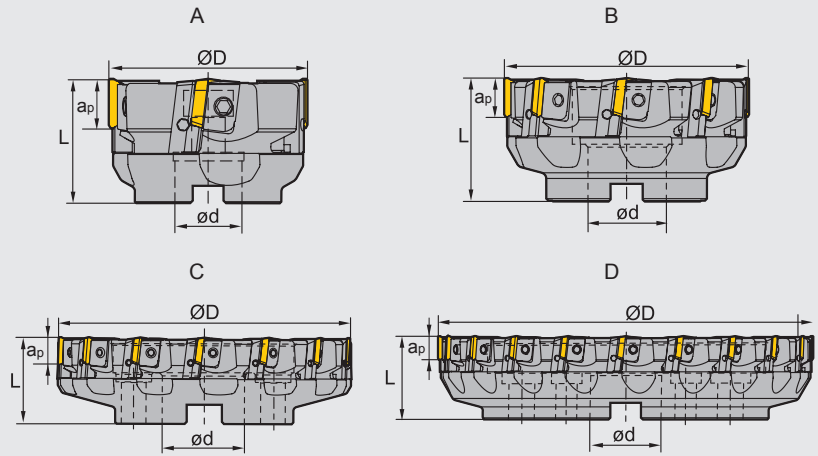

Specification of tools · Werkzeug Beschreibung

Type · Typ		Stock Lager		Dimension (mm) Abmessung				No. of teeth Zähne	Coupling Aufnahme	Weight Gewicht (kg)
		R	L	Ø D	Ø D	L	a _p max			
FMP01	-080-A27-TP22-04	●	○	80	27	50	18	4	A	1.2
	-100-B32-TP22-06	●	○	100	32	50	18	6	B	1.7
	-125-B40-TP22-08	●	○	125	40	63	18	8	B	3.2
	-160-B40-TP22-10	●	○	160	40	63	18	10	B	5.1
	-200-C60-TP22-12	●	○	200	60	63	18	12	C	7.4
	-250-C60-TP22-16	○	○	250	60	63	18	16	C	12.3
	-315-D60-TP22-20	○	○	315	60	70	18	20	D	21.9

Spare Parts · Ersatzteile

Diameter Durchmesser Ø D	Cassette Kassette	Wedge Keil	Screw Schraube	Locator screw Schraube	Wrench Schlüssel
Ø80 Ø100	LTP4R1/L1	W04R/L	WM8×17	LOM5×15.1	WT20T
Ø125 ~ Ø315	LTP4R/L		WM8×22		WT25T

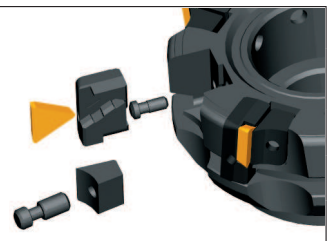

● Ex Stock / ab Lager ○ On demand / auf Anfrage

Face Milling Tools · Planfräser



FMR04 P M K

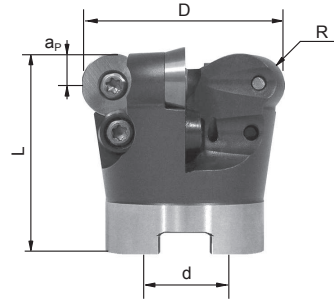

Type · Typ		Stock Lager	Dimension (mm) Abmessung					No. of teeth Zähne
			Ø D	Ø d	L	R	a _{pmax}	
FMR04	042-A16-RD1003-06	●	42	16	44	5	5	6
	052-A22-RD1003-07	●	52	22	50	5	5	7

Inserts · WSP: RDKW1003MO**

Type · Typ		Stock Lager	Dimension (mm) Abmessung					No. of teeth Zähne
			Ø D	Ø d	L	R	a _{pmax}	
FMR04	042-A16-RD12T3-05	●	42	16	42	6	6	5
	052-A22-RD12T3-05	●	52	22	50	6	6	5
	066-A27-RD12T3-06	●	66	27	50	6	6	6
	080-A27-RD12T3-07	●	80	27	50	6	6	7

Inserts · WSP: RDKW12T3MO**

Type · Typ		Stock Lager	Dimension (mm) Abmessung					No. of teeth Zähne
			Ø D	Ø d	L	R	a _{pmax}	
FMR04	*052-A22-RD1604-04	●	52	22	50	8	8	4
	*052-A22-RD1604-05	●	52	22	50	8	8	5
	066-A27-RD1604-05	●	66	27	50	8	8	5
	080-A27-RD1604-06	●	80	27	52	8	8	6
	100-B32-RD1604-07	○	100	32	52	8	8	7
	125-B40-RD1604-08	○	125	40	52	8	8	8
	160-B40-RD1604-09	○	160	40	52	8	8	9

Inserts · WSP: RDKW1604MO**

■ Spare Parts · Ersatzteile

*= WX16N (außer für FMP04-052) (except for FMP04-052)

**= nur ab (Ø 052) from (Ø 052)

Type Typ	Screw Schraube	Clamp Klemmscheibe	Clamp Screw Klemmschraube	Wrench Schlüssel
FMR04**RD1003	I60M3,5 x 7,7	-	-	WT15P
FMR04**RD12T3	I60M3,5 x 7,7	-	**LOM 3,5 x 7,1	WT15P
FMR04**RD1604	I60M4,5 x 1,0	*WX16N	-	WT20T

Applicable tool B9-B15
Werkzeug

Tools code key B22-B23
Werkzeug ISO

Grade selection guide B16-B20
Sortenauswahl

Technical data B183-B188
Technische Daten