

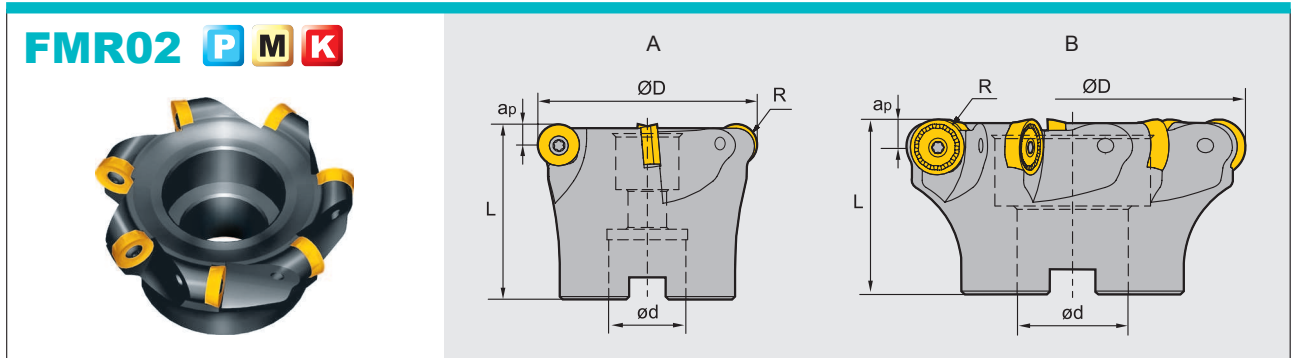



Face Milling Tools · Planfräser



Specification of tools · Werkzeug Beschreibung

Type · Typ	Stock Lager	Dimension (mm) Abmessung					No. of teeth Zähne	Coupling Aufnahme	Weight Gewicht (kg)
		Ø D	Ø D	L	R	apmax			
FMR02 050-A22-RC12-05C	○	50	22	50	6	6	5	A	0.7
052-A22-RC12-05C	○	52	22	50	6	6	5	A	0.7
063-A22-RC12-04	●	63	22	50	6	6	4	A	0.7
063-A22-RC12-06C	○	63	22	50	6	6	4	A	0.7
063-A22-RC12-06	●	63	22	50	6	6	6	A	0.7
063-A22-RC16-04	●	63	22	50	8	8	4	A	0.7
080-A27-RC12-07C	○	80	27	50	6	6	7	B	0.7
080-B27-RC16-05	●	80	27	50	8	8	5	B	0.7
080-B27-RC16-05C	○	80	27	50	8	8	5	B	0.7
080-A27-RC20-04	○	80	27	50	10	10	4	A	0.7
100-B32-RC16-06	●	100	32	63	8	8	6	B	1.2
100-B32-RC20-05	●	100	32	63	10	10	5	B	1.2
100-B32-RC20-06	○	100	32	63	10	10	6	B	1.2
125-B40-RC20-06	●	125	40	63	10	10	6	B	1.2
125-B40-RC20-07	●	125	40	63	10	10	7	B	2.2
160-B40-RC20-08	●	160	40	63	10	10	8	B	4.2
250-B40-RC20-10	○	250	40	63	10	10	10	B	

Spare Parts · Ersatzteile

Diameter Durchmesser Ø D	Insert WSP	Screw Schraube	Wrench Schlüssel	
				
Ø63-Ø80	RC12	I60M3.5×10	WT15IS	--
Ø63 - Ø100	RC16	I60M5×13	--	WT20IT
Ø80 - Ø250	RC20	I43M6×16	--	WT25IT



Applicable tool
Werkzeug **B9-B15**

Tools code key
Werkzeug ISO **B22-B23**

Grade selection guide
Sortenauswahl **B16-B20**

Technical data
Technische Daten **B183-B188**

Face Milling Tools · Planfräser



FMR04 P M K

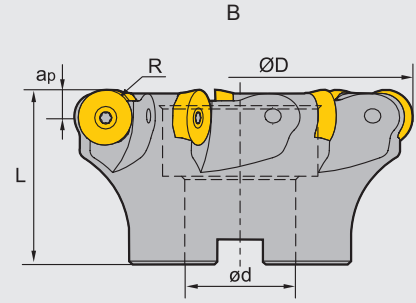
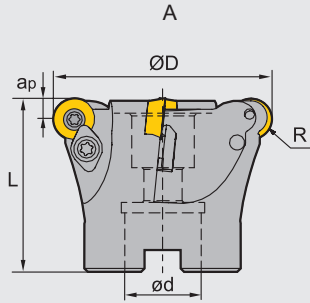

Specification of tools · Werkzeug Beschreibung

Type · Typ	Stock Lager	Dimension (mm) Abmessung					No. of teeth Zähne	Coupling Aufnahme	Weight Gewicht (kg)
		Ø D	Ø D	L	R	apmax			
FMR04									
050-A22-RD12-03	●	50	22	40	6	6	3	A	0.3
063-A22-RD12-04	●	63	22	50	6	6	4	A	0.5
080-B27-RD16-05	●	80	27	50	8	8	5	B	1.2
100-B32-RD16-06	●	100	32	50	8	8	6	B	1.0
125-B40-RD20-06	○	125	40	63	10	10	6	B	1.9
160-B40-RD20-07	○	160	40	63	10	10	7	B	3.7

Inserts · WSP: RDKW1204MO** / RDKW1605MO** / RDKW2006MO

Spare Parts · Ersatzteile

Diameter Durchmesser Ø D	Screw Schraube	Clamp Pratze	Clamp Screw Schraube (Pratze)	Wrench Schlüssel	
Ø50-Ø63	I60M3.5×10	WD-204	I60M4×10	WT15IP	--
Ø80 -Ø100	I60M5×13	--	--	--	WT20IT
Ø125 -Ø160	I43M6×16	--	--	--	WT25IT

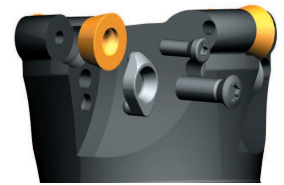

Profile milling tools · Profilfräser

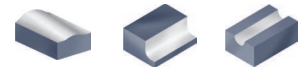

BMR01 P M K



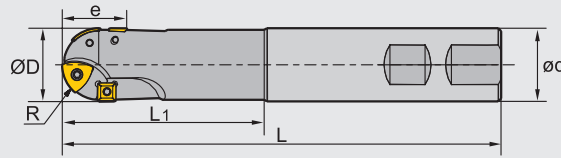

Weldon shank
Weldon Schaft



Specification of tools · Werkzeug Beschreibung

Type · Typ	Stock Lager	Dimensions (mm) · Abmessungen							Inserts · WSP				Weight Gewicht (kg)
		R	Ø D	e	ø d	L	L ₁	Type · Typ	Quantity Anzahl	Type · Typ	Quantity Anzahl		
BMR01	-020-XP20-S	○	10	20	20	20	125	50	ZDET08T2CYR10	2	SPMT060304	2	0.3
	-020-XP20-M	○	10	20	20	20	150	75	ZDET08T2CYR10	2	SPMT060304	2	0.3
	-020-XP20-L	○	10	20	20	20	200	100	ZDET08T2CYR10	2	SPMT060304	2	0.4
	-025-XP25-S	○	12.5	25	23	25	150	70	ZDET1103CYR12.5	2	SPMT060304	2	0.5
	-025-XP25-M	○	12.5	25	23	25	175	95	ZDET1103CYR12.5	2	SPMT060304	2	0.6
	-025-XP25-L	○	12.5	25	23	25	200	100	ZDET1103CYR12.5	2	SPMT060304	2	0.7
	-032-XP32-S	○	16	32	31	32	175	85	ZDET13T3CYR16	2	SDMT090308	2	0.9
	-032-XP32-M	○	16	32	31	32	200	100	ZDET13T3CYR16	2	SDMT090308	2	1.1
	-032-XP32-L	○	16	32	31	32	250	150	ZDET13T3CYR16	2	SDMT090308	2	1.4
	-040-XP40-S	○	20	40	41	40	175	85	ZPNT2204CY(R20)	3	SPMT120408	2	1.4
	-040-XP40-M	○	20	40	41	40	200	100	ZPNT2204CY(R20)	3	SPMT120408	2	1.7
	-040-XP40-L	○	20	40	41	40	250	150	ZPNT2204CY(R20)	3	SPMT120408	2	2.1
	-050-XP40-S	○	25	50	45	40	200	100	ZPNT2204CY(R25)	3	SPMT120408	2	1.8
	-050-XP40-M	○	25	50	45	40	300	100	ZPNT2204CY(R25)	3	SPMT120408	2	2.8
	-063-XP40-S	○	31.5	63	52	40	200	100	ZPNT2204CY(R31)	4	SPMT120408	2	3.0
	-063-XP40-M	○	31.5	63	52	40	300	100	ZPNT2204CY(R31)	4	SPMT120408	2	3.5

Spare parts · Ersatzteile

Diameter Durchmesser Ø D	Screw Schraube	Wrench Schlüssel	
			
Ø20-Ø25	I43M2.5×5.7	WT07IP	--
Ø32	I43M4×8	--	WT15IS
Ø40-Ø63	I43M5×11	--	WT20IS

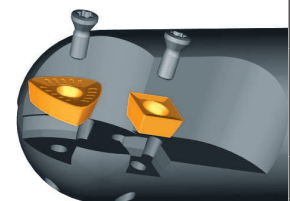

Applicable tool **B9-B15**
Werkzeug

Tools code key **B22-B23**
Werkzeug ISO

Grade selection guide **B16-B20**
Sortenauswahl

Technical data **B183-B188**
Technische Daten

Milling · Fräsen

Indexable Milling Tools · Wendepplattenfräser

Profile milling tools · Profilfräser

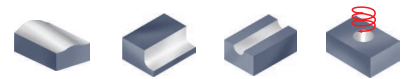

BMR03 P M K

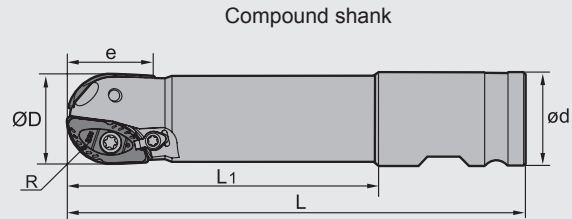

Specification of tools · Werkzeug Beschreibung

Type · Typ	Stock Lager	Dimensions (mm) · Abmessungen						No. of teeth Zähne	Weight Gewicht (kg)	Clamp Prätze	
		R	Ø D	ø d	L	L ₁	e				
BMR03	-040-XPX-M	○	20	40	50.8	250	170	40	2	1.3	CBH5R1
	-040-XPX-L	○	20	40	50.8	300	220	40	2	3.1	
	-040-XPX-XL	○	20	40	50.8	350	270	40	2	3.5	
	-050-XPX-M	○	25	50	50.8	250	170	50	2	3.1	
	-050-XPX-L	○	25	50	50.8	300	200	50	2	3.8	
	-050-XPX-XL	○	25	50	50.8	350	270	50	2	4.4	

Spare parts · Ersatzteile

Diameter Durchmesser Ø D	Clamp Prätze	Screw Schraube	Wrench Schlüssel	
Φ16	--	I60M2.5×6.5		WT07P
Φ20	--	I60M3.5×08TT	--	WT10IP
Φ25	--	I60M4×10		WT15S
Φ30	WD-208	I60M5×13	WT20IT	
Φ32	WD-208	I60M5×13		
Φ40	CBH5R1	I43M6×16	WT25IT	--
Φ50	CBH5R1	I43M8×21	WT25IT	
		I43M6×16	WT30IT	

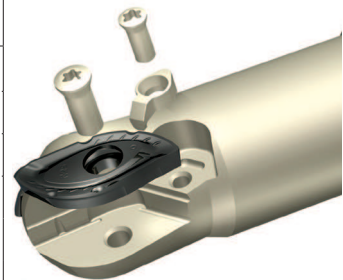

● Ex Stock / ab Lager ○ On demand / auf Anfrage

Kr:30°

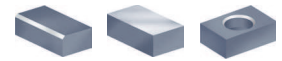

Chamfer milling tools · Fasfräser

CMZ01 **P** **M** **K**

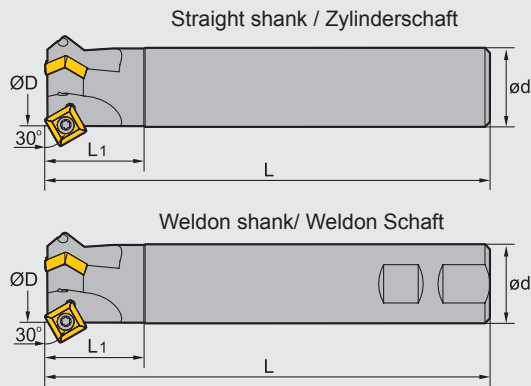

■ Specification of tools · Werkzeug Beschreibung

Type · Typ		Stock Lager	Dimensions (mm) · Abmessungen				No. of teeth Zähne	Weight Gewicht (kg)
			Ø D	ø d	L	L ₁		
CMZ01 Straight shank Zylinderschaft	-012-G20-SP12-01	●	12	20	100	40	1	0.2
	-025-G25-SP12-02	●	25	25	120	40	2	0.8
	-032-G32-SP12-03	●	32	32	180	40	3	1.1
Weldon shank	-012-XP20-SP12-01	●	12	20	100	40	1	0.2
	-025-XP25-SP12-02	●	25	25	120	40	2	0.6
Weldon Schaft	-032-XP32-SP12-03	●	32	32	180	40	3	1.0

■ Spare parts · Ersatzteile

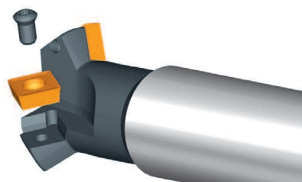
Diameter Durchmesser Ø D	Screw Schraube	Wrench Schlüssel	
Ø12-Ø32	I43M5×11	WT20IS	

Applicable tool **B9-B15**
Werkzeug

Tools code key **B22-B23**
Werkzeug ISO

Grade selection guide **B16-B20**
Sortenauswahl

Technical data **B183-B188**
Technische Daten

Kr:45°

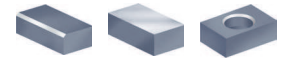

Chamfer milling tools · Fasfräser

CMA01 P M K

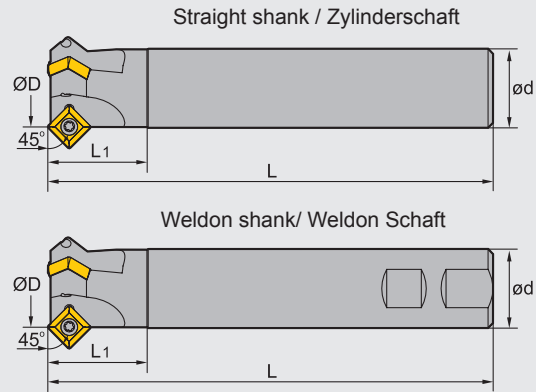

■ Specification of tools · Werkzeug Beschreibung

Type · Typ		Stock Lager	Dimensions (mm) · Abmessungen				No. of teeth Zähne	Weight Gewicht (kg)
			Ø D	ø d	L	L ₁		
CMA01 Straight shank	-012-G20-SP12-01	●	12	20	100	40	1	0.2
	-025-G25-SP12-02	●	25	25	120	40	2	0.8
	Zylinder Schaft	-032-G32-SP12-03	●	32	32	180	40	3
Weldon shank	-012-XP20-SP12-01	●	12	20	100	40	1	0.2
	-025-XP25-SP12-02	●	25	25	120	40	2	0.6
	Weldon Schaft	-032-XP32-SP12-03	●	32	32	100	40	3

■ Spare parts · Ersatzteile

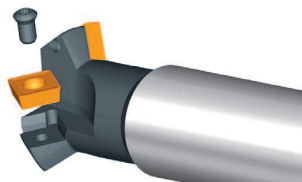
Diameter Durchmesser Ø D	Screw Schraube	Wrench Schlüssel	
Ø12-Ø32	I43M5×11	WT20IS	

● Ex Stock / ab Lager ○ On demand / auf Anfrage