

### Internal grooving and turning tools · Einstech- & Drehwerkzeuge (Innen)

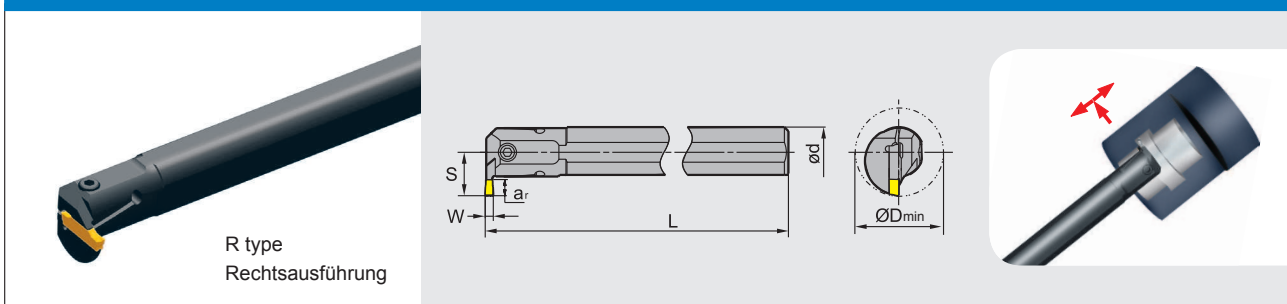

R type  
Rechtsausführung

Type · Typ	Stock		Dimension (mm) Abmessung						Inserts Stechplatte	Screw Schraube	Wrench Schlüssel
	R	L	ød	L	S	W	ar <sub>max</sub>	ØD <sub>min</sub>			
C20Q-QEDR/L05-27	●	○	20	180	15.2	2.5	5	27	ZTED02* ZRED025*	GB70-85-M4×12	WH30L
C25R-QEDR/L07-33	●	●	25	200	20.3	2.5	7	33		GB70-85-M5×16	WH40L
C32S-QEDR/L09-42	●	●	32	250	25.3	2.5	9	42	ZTFD03* ZRFD03*	GB70-85-M5×20	WH40L
C20Q-QFDR/L05-27	●	●	20	0	15.2	3	5	27		GB70-85-M4×12	
C25R-QFDR/L07-33	●	●	25	200	20.3	3	7	33	ZTGD04* ZRGD04*	GB70-85-M5×16	WH40L
C32S-QFDR/L09-42	●	●	32	250	25.3	3	9	42		GB70-85-M5×20	
C25R-QGDR/L08-35	●	●	25	200	21.5	4	8	35	ZTHD05* ZRHD05*	GB70-85-M5×16	WH40L
C32S-QGDR/L11-44	●	●	32	250	27.5	4	11	44		GB70-85-M6×20	
C40T-QGDR/L13-54	●	●	40	300	33.5	4	13	5	ZTKD06* ZRKD06*	GB70-85-M6×20	WH50L
C25R-QHDR/L08-35	○	○	25	200	21.5	5	8	35		GB70-85-M5×16	
C32S-QHDR/L11-44	●	●	32	250	27.5	5	11	44	ZTKD06* ZRKD06*	GB70-85-M6×20	WH50L
C40T-QHDR/L13-54	●	○	40	300	33.5	5	13	54		GB70-85-M6×20	
C25R-QKDR/L08-35	○	○	25	200	21.5	6	8	35	ZTKD06* ZRKD06*	GB70-85-M5×16	WH40L
C32S-QKDR/L11-44	●	●	32	250	27.5	6	11	44		GB70-85-M6×20	
C40T-QKDR/L13-54	●	●	40	300	33.5	6	13	54		GB70-85-M6×20	

### Profiling and turning tools for Al · Profildreh- & Einstechwerkzeuge für Alu (Innen)

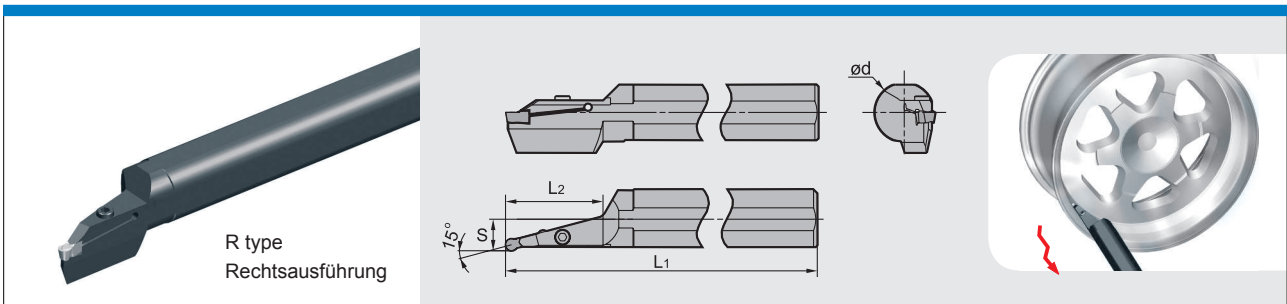

R type  
Rechtsausführung

Type · Typ	Stock		Dimension (mm) Abmessung					Inserts Stechplatten	Screw Schraube	Wrench Schlüssel
	R	L	ØD <sub>0</sub>	ød	S	L <sub>1</sub>	L <sub>2</sub>			
C40X-QLDR/L65-15A	●	●	160	40	21	320	65	ZRLD08-LH	GB70-85-M6×20	WH50L
C40X-QLDR/L80-15A	●	○	160	40	21	320	80	ZRLD08-LH		
C40X-QKDR/L60-15A	○	○	160	40	20	320	60	ZRKD06-LH		
C40X-QKDR/L75-15A	○	○	160	40	20	320	75	ZRKD06-LH		

● ex stock · ab Lager ○ on demand · auf Anfrage