

## BT CHU CNC DRILL CHUCKS

### BT 直結式鑽夾頭

BT Shank JIS B 6339(MAS 403 BT)

#### APPLICATION:

- The product can be adapted for the general lathe or the drilling processing whose machines center can supply with NT spindle.
- 適用於傳統銑床或其他提供NT主軸介面之工作母機作鑽孔加工。

#### FEATURES:

- 3 times better clamping capacity, comparing to keyed drill chucks.
- The drill bit won't be loosen or falling off.
- Twice precision than the keyed drill chucks.
- The drill chuck is interchangeable.
- 比普通夾頭多3倍的夾持力
- 鑽頭不會鬆脫或掉落
- 比普通夾頭多出2倍精準
- 可替換式的夾頭

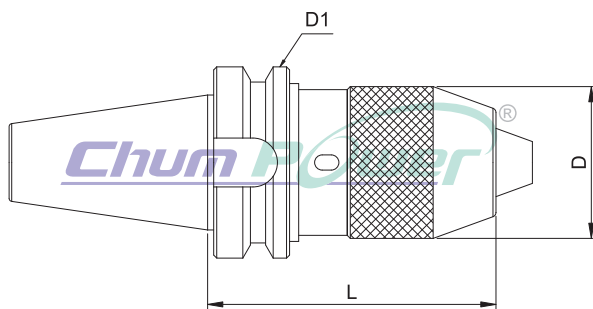

| Code NO.<br>型號 | TYPE<br>規格      | L   | D  | D1  | Spanner No.<br>扳手編號 |
|----------------|-----------------|-----|----|-----|---------------------|
| BT01005        | BT30xCHU8- 75   | 75  | 37 | 46  | 12802               |
| BT01010        | BT30xCHU13- 90  | 90  | 50 |     | 12806               |
| BT01015        | BT40xCHU8- 85   | 85  | 37 | 63  | 12802               |
| BT01025        | BT40xCHU13-95   | 95  | 50 |     | 12806               |
| BT01030        | BT40xCHU13-130  | 130 |    |     | 12806               |
| BT01035        | BT40xCHU13-150  | 150 |    |     | 12806               |
| BT01045        | BT40xCHU16-120  | 120 | 57 |     | 12808               |
| BT01050        | BT50xCHU13- 110 | 110 | 50 | 100 | 12806               |
| BT01055        | BT50xCHU13- 150 | 150 |    |     |                     |
| BT01064        | BT50xCHU16-110  | 110 | 57 |     | 12808               |
| BT01065        | BT50xCHU16-130  | 130 |    |     |                     |
| BT01070        | BT50xCHU16-145  | 145 |    |     |                     |

\*Custom-built products are available on request.

## SK CHU CNC DRILL CHUCKS

### SK 直結式鑽夾頭

SK Shank DIN 69871-A

#### FEATURES:

- 3 times better clamping capacity, comparing to keyed drill chucks.
- The drill bit won't be loosen or falling off.
- Twice precision than the keyed drill chucks.
- The drill chuck is interchangeable.
- 比普通夾頭多3倍的夾持力
- 鑽頭不會鬆脫或掉落
- 比普通夾頭多出2倍精準
- 可替換式的夾頭

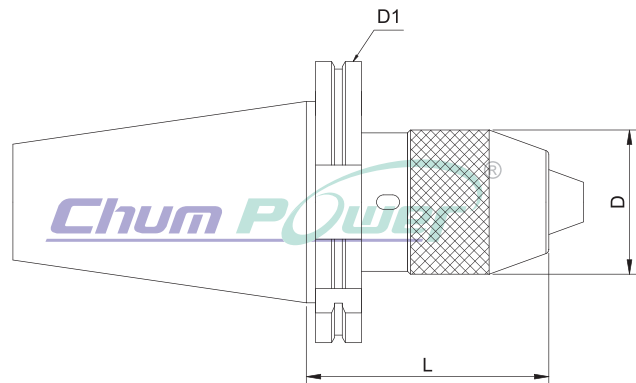

E-26

| Code NO.<br>型號 | TYPE<br>規格     | L   | D  | D1    | Spanner No.<br>扳手編號 |
|----------------|----------------|-----|----|-------|---------------------|
| SK01010        | SK30xCHU8-80   | 80  | 37 | 50    | 12802               |
| SK01020        | SK30xCHU13-100 | 100 | 50 |       | 12806               |
| SK01030        | SK30xCHU16-125 | 125 | 57 |       | 12808               |
| SK01040        | SK40xCHU8-75   | 75  | 37 | 63.55 | 12802               |
| SK01050        | SK40xCHU13-100 | 100 | 50 |       | 12806               |
| SK01060        | SK40xCHU16-115 | 115 | 57 |       | 12808               |
| SK01070        | SK50xCHU13-100 | 100 | 50 | 97.5  | 12806               |
| SK01080        | SK50xCHU16-105 | 105 | 57 |       | 12808               |

\*Custom-built products are available on request.